

**GENERAL:**

The surface drainage system shall be Trench Drain - V-Bottom, to be used with trench grates as manufactured by FoodSafe Drains.

**MATERIALS:**

- 14 ga. T304 Stainless Steel
- T316 Stainless Steel

**SLOPE:** 0.5% Standard

**DESIGN OPTIONS:**

- Material(\$): SS 304(5), SS 316(6)
- End(\*): Open(0), End Cap(1), Flush Nipple(5)
- Trench Grate Height(^): 1/4" w Spacer to 2"
- Trench Grate Width(#): 6", 8", 10", 12", 14", 16"
- Outlet Diameter: 3", 4", 6"
- Standard Lengths: 9' 8", 4' 10"
- Custom Lengths Available

**GRATES:**

Bar Grate with Optional Serration/Antislip Design

**LOAD CLASS:** A15 to E600 Available

**INSTALLATION:**

The Trench Drain - V-Bottom shall be installed in accordance with the manufacturer's installation instructions and recommendations. Trench sections are manufactured with leveling bars and flanges to secure the drain within the concrete slab.

**TYPICAL MODULAR LAYOUT OF A FOODSAFE TRENCH DRAIN - V-BOTTOM**

(Sections fit together as illustrated below)

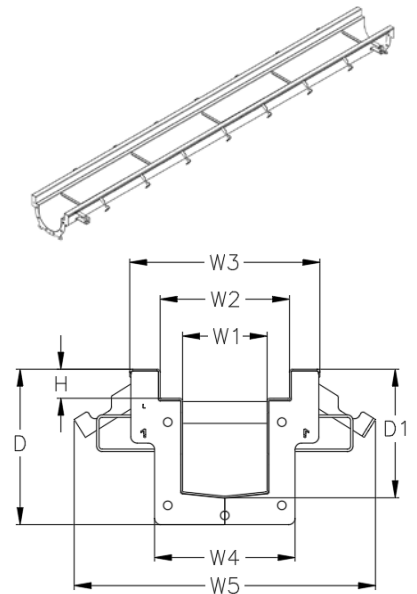
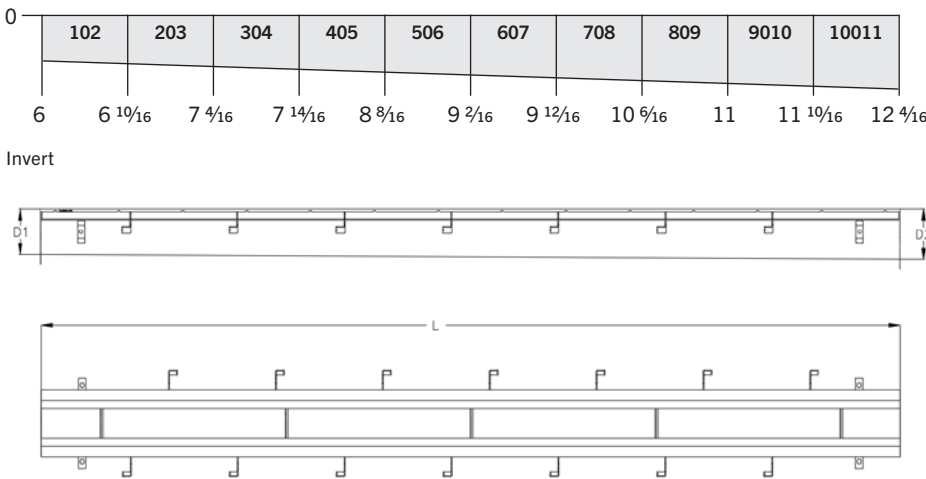

DRAIN CHANNELS DESCRIPTION	PART NUMBER	INVERT SHALLOW (INCHES D1)	INVERT DEEP (INCHES D2)
FSD TRENCH - V-BOTTOM 102	FTV\$^*^#-L102	6	6 10/16
FSD TRENCH - V-BOTTOM 203	FTV\$^*^#-L203	6 10/16	7 4/16
FSD TRENCH - V-BOTTOM 304	FTV\$^*^#-L304	7 4/16	7 14/16
FSD TRENCH - V-BOTTOM 405	FTV\$^*^#-L405	7 14/16	8 8/16
FSD TRENCH - V-BOTTOM 506	FTV\$^*^#-L506	8 8/16	9 2/16
FSD TRENCH - V-BOTTOM 607	FTV\$^*^#-L607	9 2/16	9 12/16
FSD TRENCH - V-BOTTOM 708	FTV\$^*^#-L708	9 12/16	10 6/16
FSD TRENCH - V-BOTTOM 809	FTV\$^*^#-L809	10 6/16	11
FSD TRENCH - V-BOTTOM 9010	FTV\$^*^#-L9010	11	11 10/16
FSD TRENCH - V-BOTTOM 10011	FTV\$^*^#-L10011	11 10/16	12 4/16

NOTE: Catch Basins are available in any custom dimensions. Also available with 90° sections, 'T' sections, and Transition Pits for all of the depths specified above.

Specifying engineer is responsible for concrete encasement and reinforcing based upon application and local codes. FoodSafe Drains reserves the right to change the product and specifications without notice.