

GENERAL:

The surface drainage system shall be 10,000S Series FoodSafe Slot Drain complete with slotted linear trench opening as manufactured by FoodSafe Drains.

MATERIALS

- T304 Stainless Steel
- T316 Stainless Steel

SLOPE: 0.5% Standard

DESIGN OPTIONS:

- Material(\$): SS 304(5), SS 316(6)
- Slot Opening(#): 13mm(0), 25mm(1), 32mm (5)
- End(*): Open(0), End Cap(1), Flush Nipple(5)
- Section Lengths: Full 2946mm, Half 1473mm
- Custom Lengths Available

FLOW RATE:

- 13mm 42 lpm (per 305mm of drain)
- 25mm 68 lpm (per 305mm of drain)
- 32mm 102 lpm (per 305mm of drain)

LOAD CLASS:

- DIN EN 1433 - Load Class E
- ASME 112.6.3 - Extra Heavy Duty

ACCESSORIES:

Cleaning Paddle, Cleaning Brush, Flush Flo, Slot Hog, KeyForm

INSTALLATION:

The 10,000S Series FoodSafe Slot Drain shall be installed in accordance with the manufacturer's installation instructions and recommendations.

TYPICAL MODULAR LAYOUT

(Sections fit together as illustrated below)

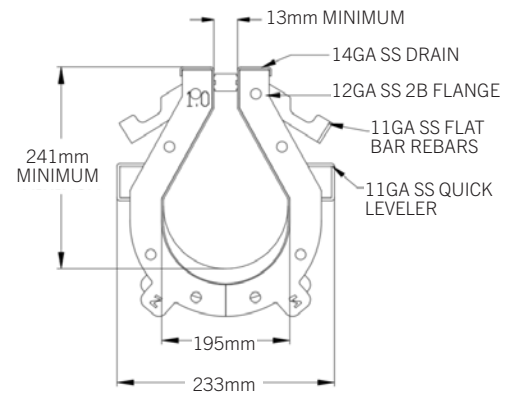
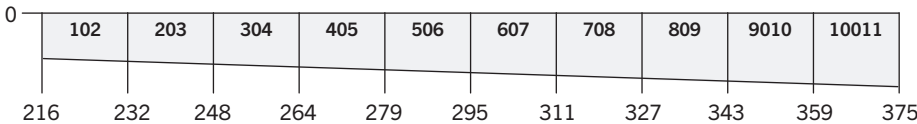

DRAIN CHANNELS DESCRIPTION	PART NUMBER	INVERT SHALLOW (mm)	INVERT DEEP (mm)
10000S SERIES SS SLOT 102 HALF	SD10\$*#S-102B	224	232
10000S SERIES SS SLOT 102	SD10\$*#S-102	216	232
10000S SERIES SS SLOT 203	SD10\$*#S-203	232	248
10000S SERIES SS SLOT 304	SD10\$*#S-304	248	264
10000S SERIES SS SLOT 405	SD10\$*#S-405	264	279
10000S SERIES SS SLOT 506	SD10\$*#S-506	279	295
10000S SERIES SS SLOT 607	SD10\$*#S-607	295	311
10000S SERIES SS SLOT 708	SD10\$*#S-708	311	327
10000S SERIES SS SLOT 809	SD10\$*#S-809	327	343
10000S SERIES SS SLOT 9010	SD10\$*#S-9010	343	359
10000S SERIES SS SLOT 10011	SD10\$*#S-10011	359	375

NOTE: Also available with 90° sections, 'T' sections, and Transition Pits for all of the depths specified above.

CATCH BASIN DESCRIPTION	TOP WIDTH (mm)	TOP LENGTH (mm)	BOTTOM WIDTH (mm)	BOTTOM LENGTH (mm)	HEIGHT (mm)	OUTLET SIZE (mm)
10000 SS SMALL	314	314	314	314	435	102 or 152
10000 SS LARGE	314	314	314	314	530	102 or 152

Specifying engineer is responsible for concrete encasement and reinforcing based upon application and local codes. FoodSafe Drains reserves the right to change the product and specifications without notice.