

REVISIONS			
REV	DESCRIPTION	DATE	BY
0	INITIAL RELEASE - RO	11/12/2025	DK

NOTES: UNLESS OTHERWISE SPECIFIED

1. ALL DIMENSIONS ARE IN INCHES.
2. DRAIN BODY MATERIAL: 16GA STAINLESS STEEL T304/316.
3. HEEL-PROOF EXTENSION CAN BE EXTENDED TO THE FLOOR FINISH LEVEL.
4. SPECIFYING ENGINEER IS RESPONSIBLE FOR CONCRETE ENCASEMENT AND REINFORCING BASED UPON APPLICATION AND LOCAL CODES.
5. REFER TO <https://info.slotdrainsystems.com/installresources> FOR INSTALLATION INSTRUCTIONS.

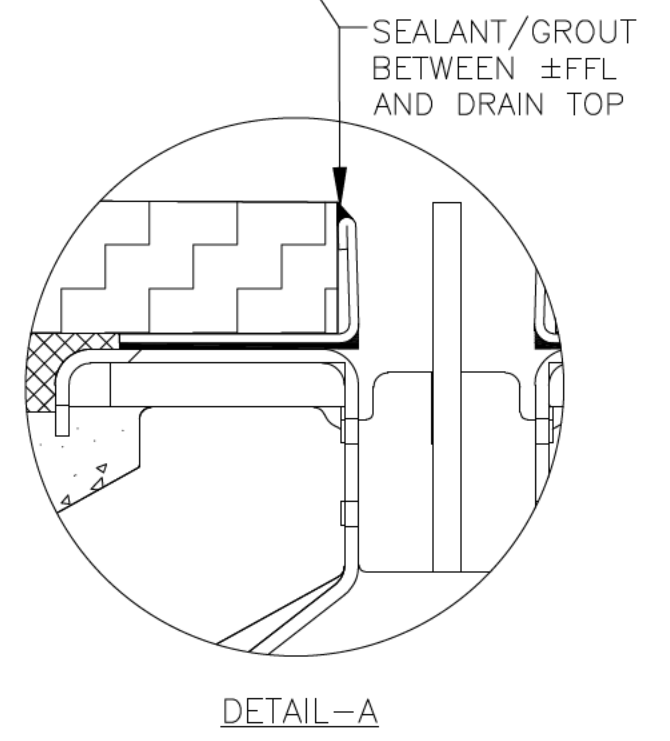
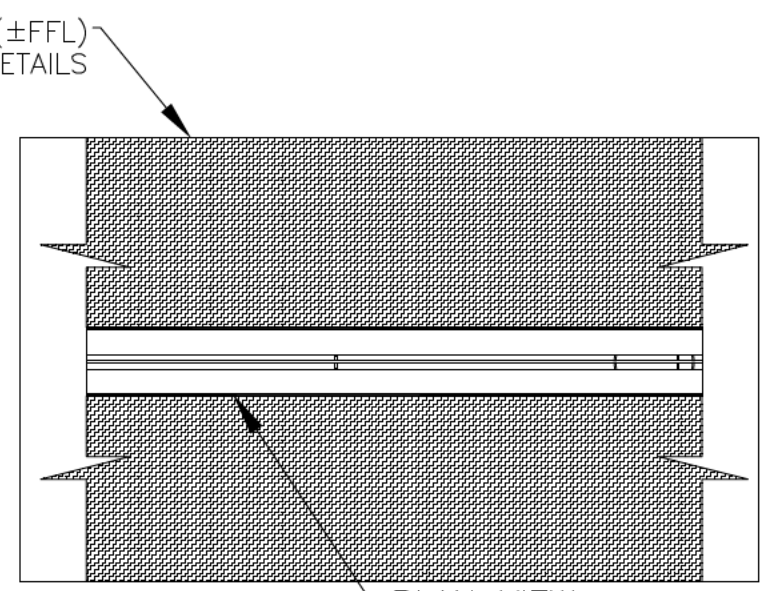
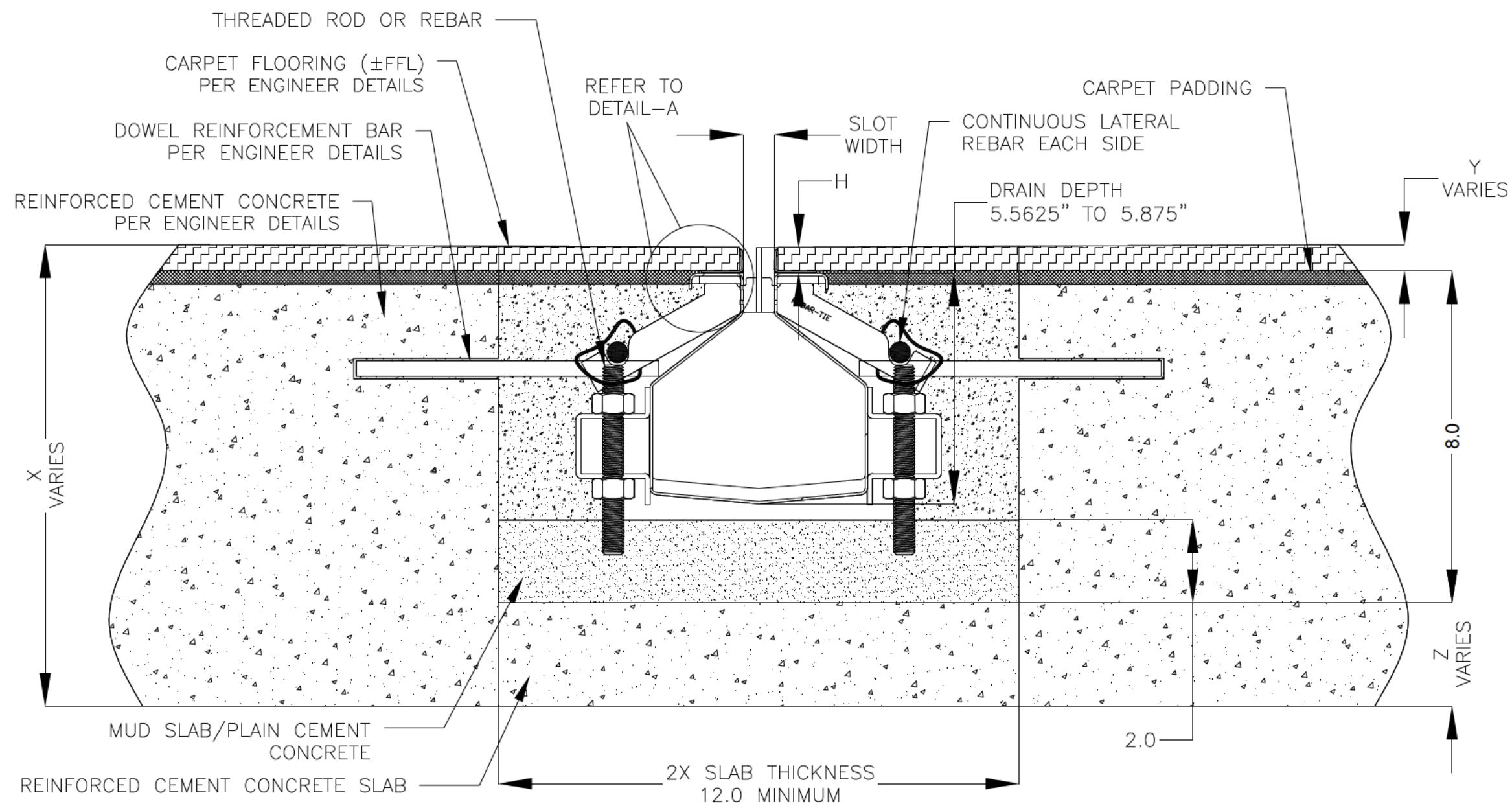

2000 SERIES ELEVATOR DUAL SLOT DRAIN INSTALLATION DETAILS



DRAWING TITLE
CARPET FLOOR-RETROFIT INSTALLATION

DRAIN SERIES
2000 SERIES ELEVATOR DUAL SLOT DRAIN

DWG NO. IN-SD26031-H-102-RO SIZE B SCALE NTS SHEET 1 OF 1

ALL DRAWINGS ARE THE EXCLUSIVE PROPERTY OF SLOT DRAIN SYSTEMS. ANY REPRODUCTION IN PART OR IN WHOLE IS PROHIBITED WITHOUT PROPER CONSENT.