

REVISIONS			
REV	DESCRIPTION	DATE	BY
0	INITIAL RELEASE - RO	6/18/2024	DK

NOTES: UNLESS OTHERWISE SPECIFIED

1. ALL DIMENSIONS ARE IN INCHES.
2. DRAIN BODY MATERIAL: 16GA STAINLESS STEEL T316
3. SPECIFYING ENGINEER IS RESPONSIBLE FOR CONCRETE ENCASEMENT AND REINFORCING BASED UPON APPLICATION AND LOCAL CODES.
4. REFER TO <https://info.slotdrainsystems.com/installresources> FOR INSTALLATION INSTRUCTIONS.

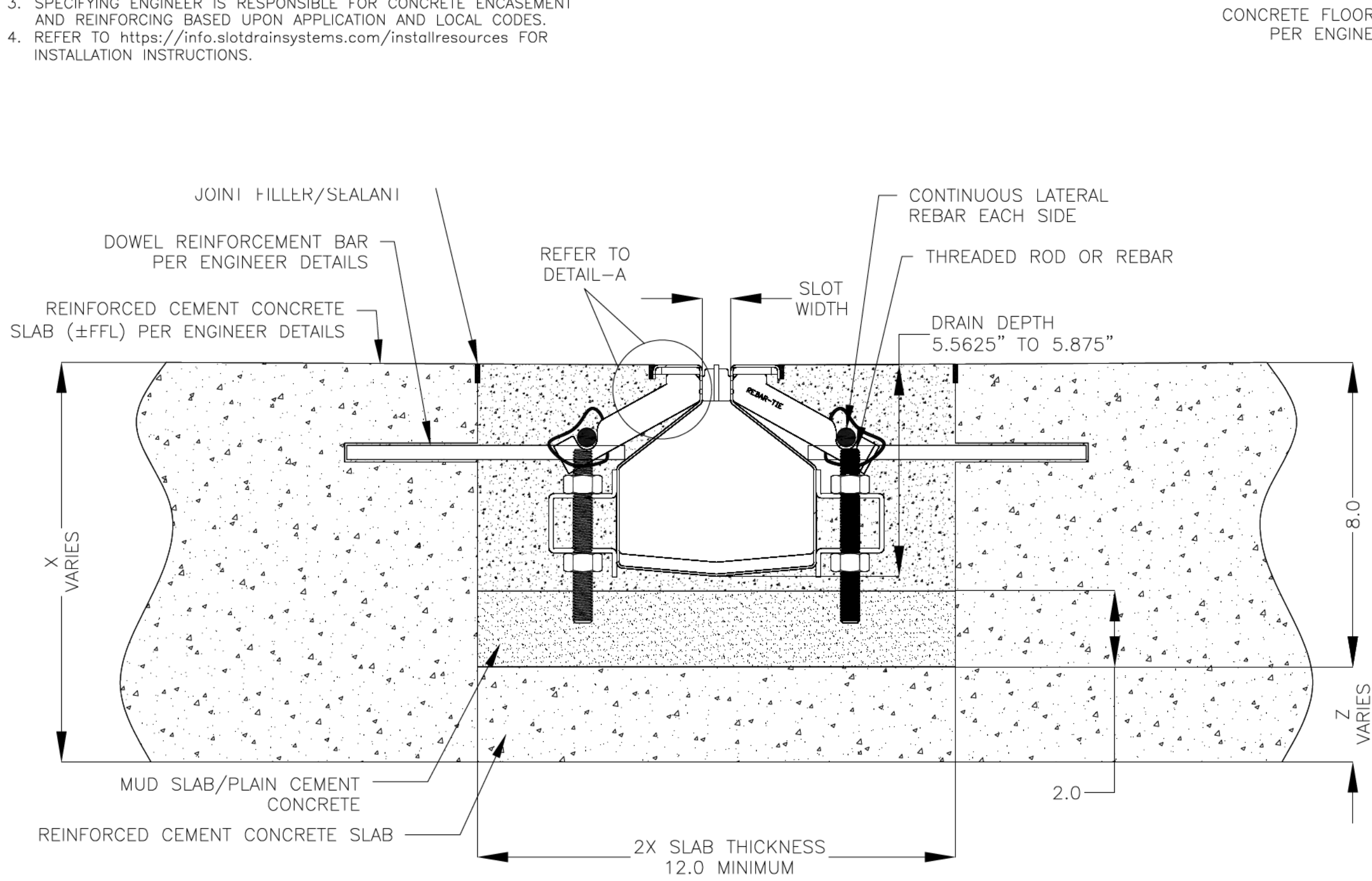

CONCRETE FLOORING (\pm FFL)
PER ENGINEER DETAILS

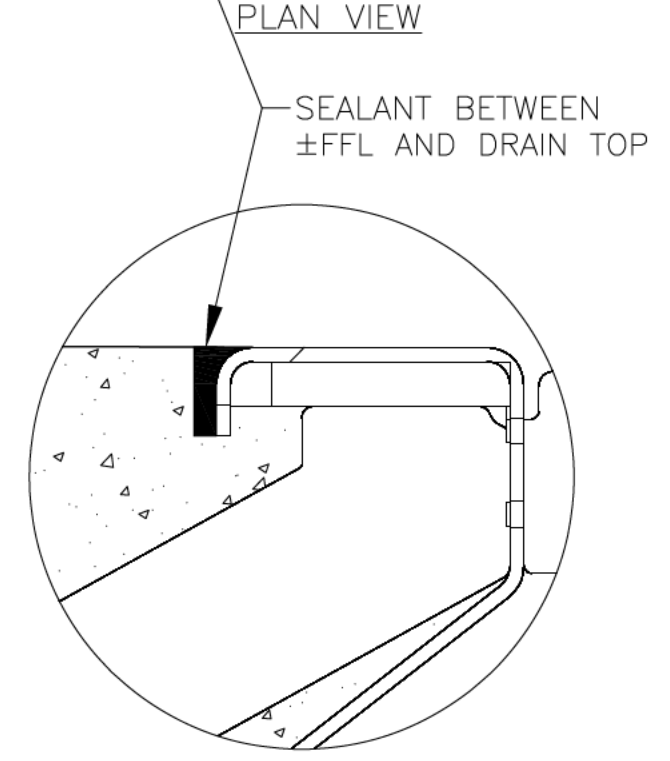
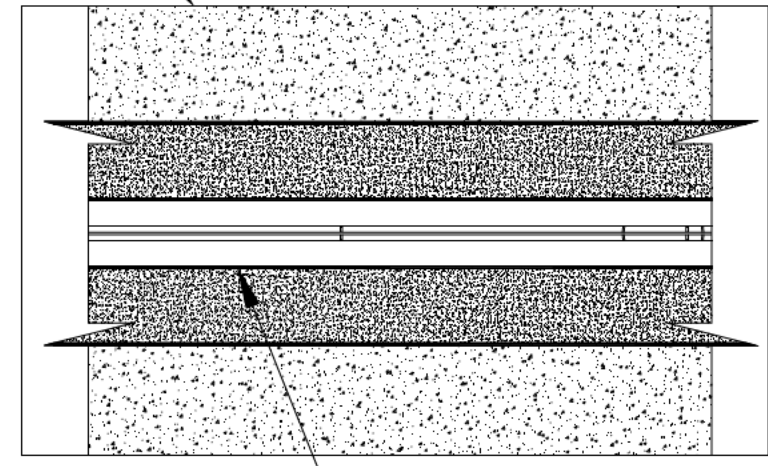

2000 SERIES ELEVATOR DUAL SLOT DRAIN INSTALLATION DETAILS



DRAWING TITLE
CONCRETE FLOOR-RETROFIT INSTALLATION

DRAIN SERIES
2000 SERIES ELEVATOR DUAL SLOT DRAIN

DWG NO. IN-SD26031-0-100-RO SIZE B SCALE NTS SHEET 1 OF 1

ALL DRAWINGS ARE THE EXCLUSIVE PROPERTY OF SLOT DRAIN SYSTEMS. ANY REPRODUCTION IN PART OR IN WHOLE IS PROHIBITED WITHOUT PROPER CONSENT.